



2016 FOCUS ELECTRIC VEHICLE (EV)



EMERGENCY RESPONSE GUIDE

Table of Contents

FOREWORD	Page 1
ELECTRIC VEHICLE IDENTIFICATION	Page 2
VIN Layout.....	Page 3
HIGH-VOLTAGE ELECTRICAL DISCONNECT FEATURES.....	Page 4
HIGH-VOLTAGE WARNING DECALS	Page 5
COMPONENT LOCATION AND IDENTIFICATION	Page 6-8
HIGH-VOLTAGE SERVICE DISCONNECT.....	Page 9
Upper High-Voltage Battery Service Disconnect.....	Page 9-10
Lower High-Voltage Battery Service Disconnect	Page 11
HIGH-VOLTAGE BATTERY PACKS.....	Page 12-13
APPROACHING A DAMAGED HIGH-VOLTAGE VEHICLE	Page 13-18
Follow Existing Training and Incident Commander Direction	Page 14
Approaching a Damaged Vehicle.....	Page 15
High Voltage System - Do Not Cut Zones	Page 16
If The High-Voltage Battery Case Has Been Ruptured.....	Page 17
Moving Damaged Vehicles - Tow Truck Drivers	Page 17-18
Electric and Hybrid Electric Vehicle Considerations	Page 18
DAMAGED VEHICLE GUIDANCE FOR FORD MOTOR COMPANY ELECTRIC AND HYBRID-ELECTRIC VEHICLES EQUIPPED WITH HIGH VOLTAGE BATTERIES.....	Page 19-21
DAMAGED BATTERY ELECTRIC VEHICLE STORAGE PLACARD	Page 22

FOREWORD

The emergency response procedures for the Focus electric vehicle are similar to those for hybrid electric vehicles with the same considerations for the high-voltage electric system components.

The Focus electric vehicle uses an electric motor to power the vehicle. Electricity is stored in high-voltage battery packs.

The system incorporates a generator function in the electric motor that recharges the high-voltage batteries during cruising and braking.

The information in this guide will help provide a safe response to emergencies involving Focus electric vehicles.

The Focus electric vehicle has been designed with many safety features for your protection. These features help provide safe access to the vehicle under various conditions. However when approaching a high-voltage vehicle in a fire, rescue or recovery situation, always follow one industry standard rule:

***ALWAYS ASSUME THE VEHICLE'S
HIGH-VOLTAGE SYSTEM IS POWERED UP !***



ELECTRIC VEHICLE (EV) IDENTIFICATION

Focus electric vehicles are identified by the Electric badges located on the left and right front doors. There is an Electric nameplate on the trunk lid that also includes the green leaf/blue highway icon.



Electric nameplate and icon on the front doors.

Electric nameplate and icon on the trunk lid.

ELECTRIC VEHICLE IDENTIFICATION (CONTINUED)

- The Focus electric powertrain is identified by the orange high-voltage underhood cabling.

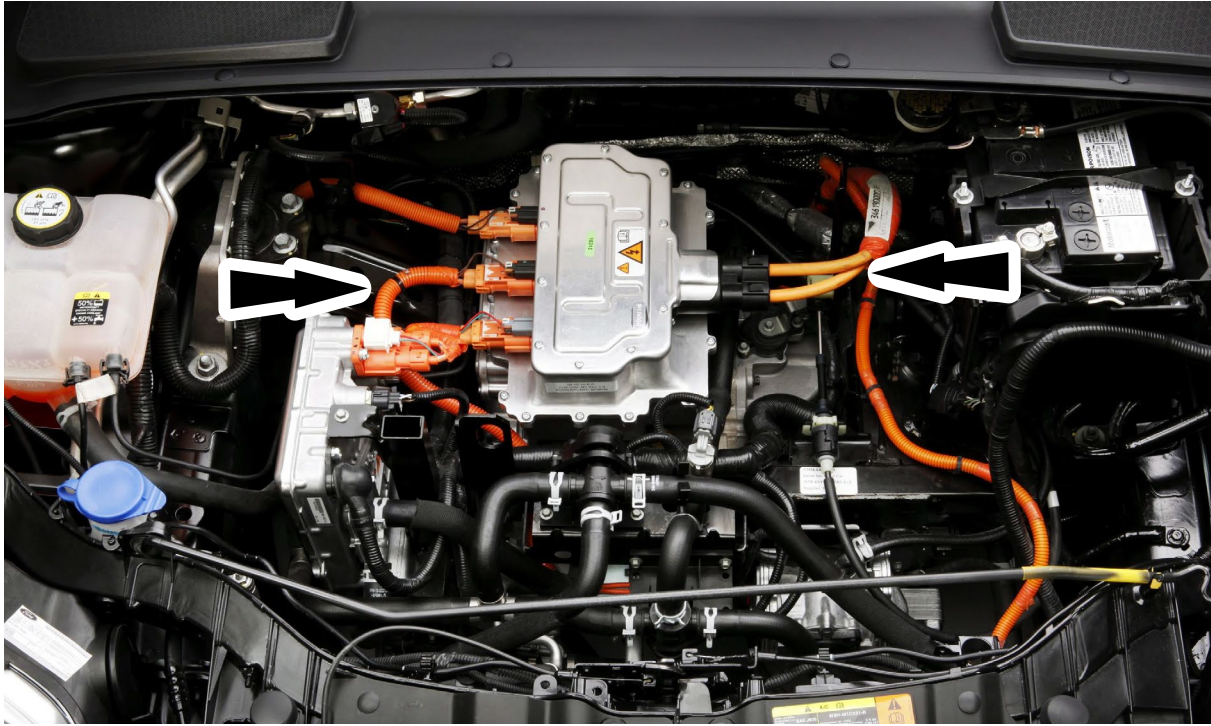

Orange high-voltage cabling from the high-voltage battery packs

- The 5th, 6th and 7th digits of the Vehicle Identification Number (VIN) identify the Focus electric.

VIN POSITIONS 5, 6 and 7	VEHICLE
P3R	Focus Electric

SAMPLE VIN

1 F A D P 3 R 1 0 A R 1 0 0 0 0 1

↑ ↑
Focus Electric

HIGH-VOLTAGE ELECTRICAL DISCONNECT FEATURES



WARNING: ELECTRIC VEHICLES DAMAGED BY A CRASH MAY HAVE COMPROMISED HIGH VOLTAGE SAFETY SYSTEMS AND PRESENT A POTENTIAL HIGH VOLTAGE ELECTRICAL SHOCK HAZARD. EXERCISE CAUTION AND WEAR APPROPRIATE PERSONAL PROTECTIVE EQUIPMENT (PPE) INCLUDING HIGH VOLTAGE SAFETY GLOVES AND BOOTS. REMOVE ALL METALLIC JEWELRY, INCLUDING WATCHES AND RINGS. ISOLATE THE HIGH VOLTAGE SYSTEM AS DIRECTED BY THE FORD EMERGENCY RESPONSE GUIDE FOR THE VEHICLE. FAILURE TO FOLLOW THESE INSTRUCTIONS MAY RESULT IN SERIOUS PERSONAL INJURY OR DEATH.

The following features have been incorporated into Focus electric vehicles to allow for either simple or automatic shut-off of the high-voltage electrical systems.

- High-voltage fuse — In the event of a high-voltage short circuit, the high-voltage fuse opens, isolating the high-voltage system.
- High-voltage interlock circuit — Whenever a high-voltage connector is disconnected, the high-voltage interlock circuit opens and isolates the high-voltage system. The circuit will also open if a high-voltage cable is cut, broken, or severed. This circuit is wrapped around high-voltage cables.
- Ignition is in the OFF position when the vehicle ready light is off. Any time the ready light is off, the high-voltage system is isolated. If the vehicle ready light is on, press the start button to turn off the ignition.
- Battery high-voltage service disconnect — Whenever either of the battery high-voltage service disconnects are removed, the high-voltage system is isolated. For additional information, refer to High Voltage Service Disconnect in this manual.
- Thermal sensors — If the battery is exposed to hot ambient conditions and/or is being driven aggressively with compromised cooling, power limits will be employed to prevent overheating. However, if the battery is in use and becomes too hot, contacts will open and the vehicle will shut down.

HIGH-VOLTAGE WARNING DECALS

- On Ford electric vehicles, WARNING decals are located on high-voltage components in the high-voltage system throughout the vehicle. See the following example.

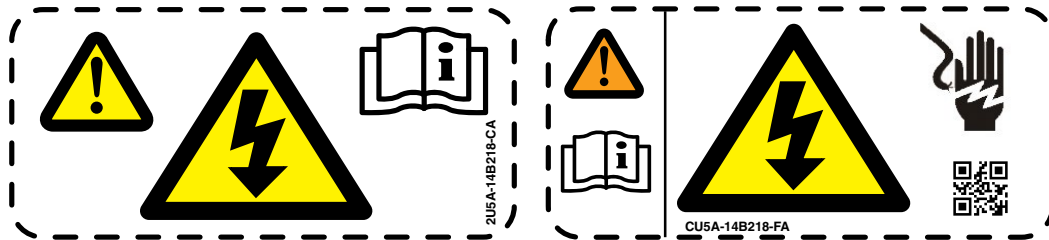

⚠ WARNING: HIGH VOLTAGE VEHICLE ⚠	
<p>TO REDUCE THE RISK OF POSSIBLE SERIOUS INJURY (SHOCK OR BURN) OR DEATH: COMPONENTS MARKED WITH THE HIGH VOLTAGE SYMBOL ⚠ CONTAIN HIGH VOLTAGE AND HIGH TEMPERATURES AND SHOULD BE AVOIDED. SERVICE MUST BE PERFORMED BY QUALIFIED PERSONNEL ONLY. 📖</p>	
⚠ AVERTISSEMENT : CIRCUITS HAUTE TENSION DU VÉHICULE ⚠	
<p>POUR RÉDUIRE LES RISQUES DE BLESSURES GRAVES (CHOCs OU BRÛLURES) OU MORTELLES : LES ÉLÉMENTS ACCOMPAGNÉS DU SYMBOLE HAUTE TENSION ⚠ ONT UNE TENSION ET DES TEMPÉRATURES ÉLEVÉES ET DOIVENT ÊTRE ÉVITÉS. 📖</p> <p>LA RÉPARATION ET L'ENTRETIEN DOIVENT ÊTRE EFFECTUÉS PAR UN TECHNICIEN QUALIFIÉ SEULEMENT. 4L8A-14B218-AB</p>	

COMPONENT LOCATION AND IDENTIFICATION

The following illustrations provide the location, description and basic function of the Focus electric system components.

NOTE: All high-voltage wires and harnesses are wrapped in orange insulation.

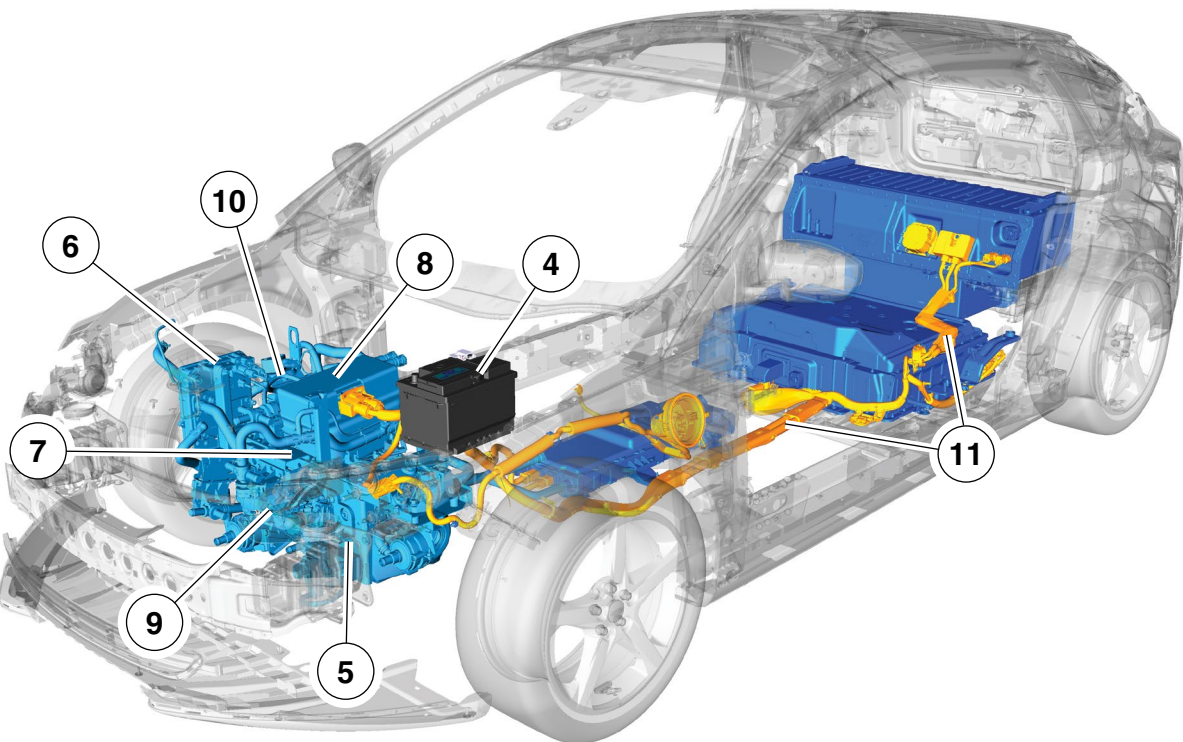
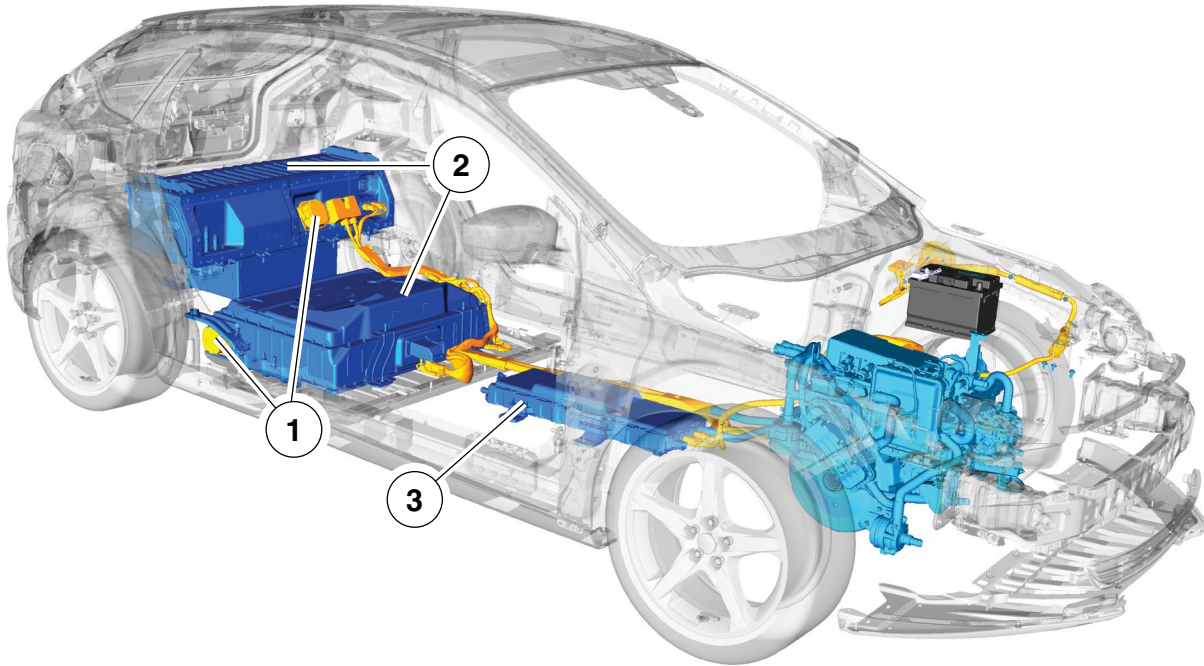

COMPONENT LOCATION AND IDENTIFICATION (CONTINUED)

	COMPONENT	LOCATION / DESCRIPTION	FUNCTION
1	High-voltage service disconnects	Upper service disconnect is located behind the rear backrest. Lower service disconnect is below the upper pack near the Right Hand (RH) rear tire. Orange in color with a square body design. Uses a two-stage release tab.	Provides the way to safely disconnect the high-voltage batteries.
2	High-voltage battery	Located behind the rear backrest and under the vehicle. Liquid cooled/heated lithium ion.	Provides high-voltage storage for the vehicle's electric motor.
3	Secondary On-Board Diagnostic Module (SOBDM) (High Voltage Battery Charger)	Located under the vehicle aft of the engine compartment. Has both low and high voltage electrical connections.	Charges both the high-voltage battery and the low-voltage (12-volt) battery.
4	12-volt battery	Located under the hood on the driver side of the vehicle. Typical automotive 6-cell lead/acid design.	Provides 12 volts for vehicle accessories.
5	Single speed automatic transmission (gearbox)	Transverse-mounted design, similar to non-electric Focus vehicles. Attached to the traction motor.	Provides rotational force to the wheels for vehicle propulsion.
6	DC/DC converter	Located under the hood on the passenger side, next to the washer fluid reservoir. Has orange high-voltage wires and Motor Electronics Cooling System (MESC) hoses attached.	Provides 12 volts to charge the 12-volt battery and run vehicle accessories.

COMPONENT LOCATION AND IDENTIFICATION (CONTINUED)

	COMPONENT	LOCATION / DESCRIPTION	FUNCTION
7	Electric motor	Liquid cooled 3-phase AC permanent magnet motor. Attached to the gearbox centrally located in the engine compartment	Turns energy from the high-voltage traction battery into movement that is applied to the transmission for vehicle propulsion.
8	Transmission Control Module (TCM)	Located on top of the electric motor. Hall-effect sensor type module.	The TCM controls the motor/inverters to produce the desired torque output to the wheels.
9	Electric air conditioning compressor	Located in front of the motor. Has an orange high-voltage wire attached to it using an interlock connector.	Replaced the belt driven motor.
10	PTC heater cabin coolant heater	Located on the RH side of the motor near the DC/DC converter. Has both high and low voltage electrical connection	Increases the coolant temperature to normal operating temperature.
11	High-voltage wiring	Runs along the vehicle's floorpan from the high-voltage compartment. All high-voltage wiring has orange-colored insulation.	Provides the physical connection between the high-voltage and the vehicles high-voltage equipment.

UPPER BATTERY HIGH-VOLTAGE SERVICE DISCONNECT

⚠ WARNING: ELECTRIC VEHICLES DAMAGED BY A CRASH MAY HAVE COMPROMISED HIGH VOLTAGE SAFETY SYSTEMS AND PRESENT A POTENTIAL HIGH VOLTAGE ELECTRICAL SHOCK HAZARD. EXERCISE CAUTION AND WEAR APPROPRIATE PERSONAL PROTECTIVE EQUIPMENT (PPE) INCLUDING HIGH VOLTAGE SAFETY GLOVES AND BOOTS. REMOVE ALL METALLIC JEWELRY, INCLUDING WATCHES AND RINGS. ISOLATE THE HIGH VOLTAGE SYSTEM AS DIRECTED BY THE FORD EMERGENCY RESPONSE GUIDE FOR THE VEHICLE. FAILURE TO FOLLOW THESE INSTRUCTIONS MAY RESULT IN SERIOUS PERSONAL INJURY OR DEATH.

NOTE : Lower the rear 60% seat backrest to access the upper battery high-voltage service disconnect.

1. Locate the seat backrest release lever at the top of the backrest.
2. Push the release lever at the top of the backrest.

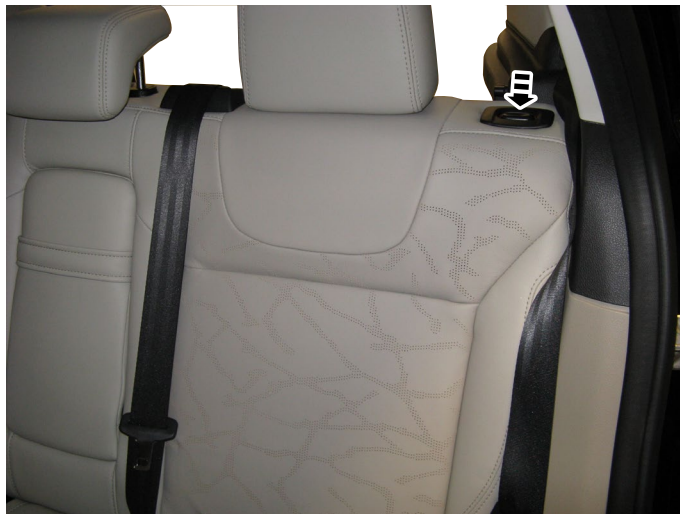

3. Remove the cover to access the upper battery high-voltage service disconnect.

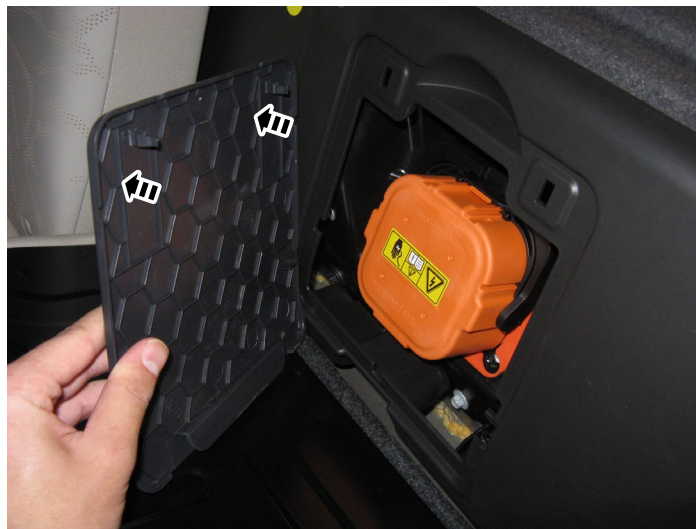

UPPER BATTERY HIGH-VOLTAGE SERVICE DISCONNECT (CONTINUED)

4. Press the release tab at the top of the upper high-voltage battery service disconnect and rotate the release handle down approximately 45 degrees.



5. Press the release tab again and rotate the handle another 45 degrees to the fully released position. Pull out on the handle to remove the upper battery high-voltage service disconnect.



LOWER BATTERY HIGH-VOLTAGE SERVICE DISCONNECT

NOTE : The lower battery high-voltage service disconnect is removed in the same way as the upper battery high-voltage service disconnect. To gain access to the lower battery high-voltage service disconnect, raise the rear of the vehicle using a suitable jack.

NOTE : The lower battery high-voltage service disconnect is located on the passenger side of the vehicle near the rear tire.

1. Remove the parking brake cable bracket retainer and position the parking brake cable and bracket aside.
2. Press the release tab at the rear of the service disconnect, and rotate the release handle approximately 45 degrees towards the front of the vehicle.
3. Press the release tab again, and rotate the release handle another 45 degrees to the fully released position.
4. Pull the handle to remove the lower battery high-voltage service disconnect.

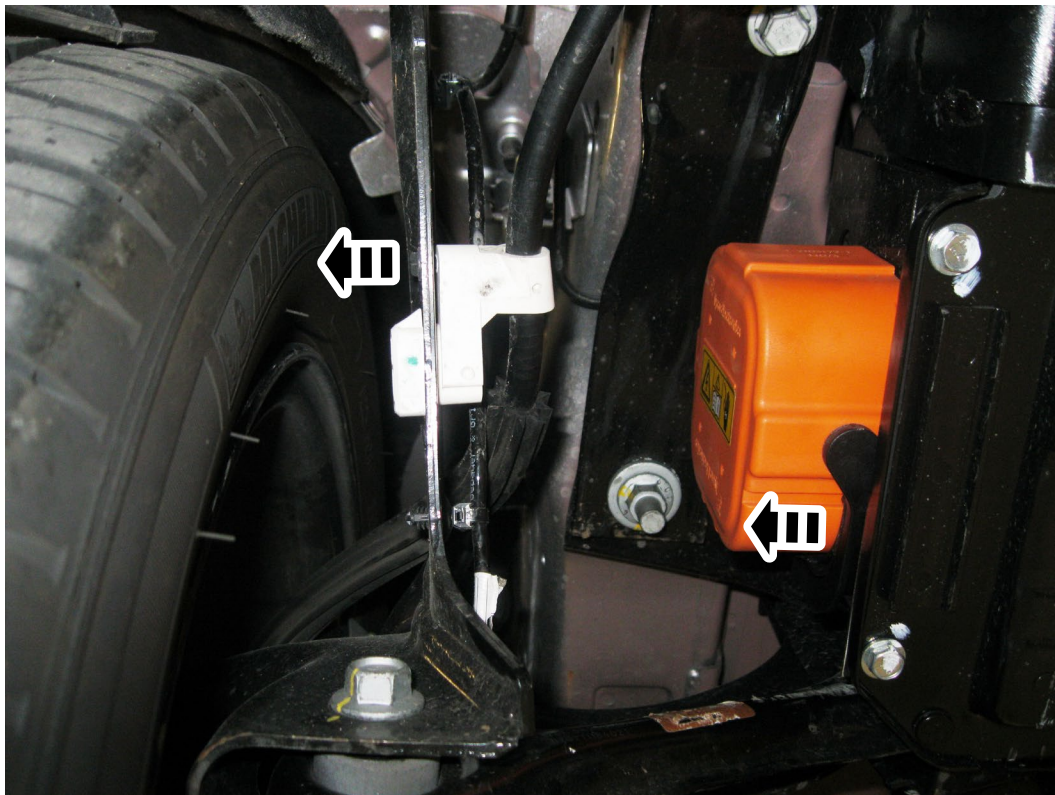

HIGH-VOLTAGE BATTERY PACKS

 **WARNING:** ELECTRIC VEHICLES DAMAGED BY A CRASH MAY HAVE COMPROMISED HIGH VOLTAGE SAFETY SYSTEMS AND PRESENT A POTENTIAL HIGH VOLTAGE ELECTRICAL SHOCK HAZARD. EXERCISE CAUTION AND WEAR APPROPRIATE PERSONAL PROTECTIVE EQUIPMENT (PPE) INCLUDING HIGH VOLTAGE SAFETY GLOVES AND BOOTS. REMOVE ALL METALLIC JEWELRY, INCLUDING WATCHES AND RINGS. ISOLATE THE HIGH VOLTAGE SYSTEM AS DIRECTED BY THE FORD EMERGENCY RESPONSE GUIDE FOR THE VEHICLE. FAILURE TO FOLLOW THESE INSTRUCTIONS MAY RESULT IN SERIOUS PERSONAL INJURY OR DEATH.

 **WARNING:** FIRES IN CRASH-DAMAGED ELECTRIC VEHICLES MAY EMIT TOXIC OR COMBUSTIBLE GASSES. SMALL AMOUNTS OF EYE, SKIN OR LUNG IRRITANTS MAY BE PRESENT. WEAR PERSONAL PROTECTIVE EQUIPMENT (PPE) AND SELF-CONTAINED BREATHING APPARATUS WHEN WORKING IN CLOSE PROXIMITY OR IN A CONFINED AREA, SUCH AS A TUNNEL OR GARAGE. VENTILATE THE VEHICLE INTERIOR BY OPENING VEHICLE WINDOWS OR DOORS. VENTILATE THE WORKING AREA. FAILURE TO FOLLOW THIS INSTRUCTION MAY RESULT IN SERIOUS PERSONAL INJURY OR DEATH.

 **WARNING:** REMOVING THE BATTERY HIGH-VOLTAGE SERVICE DISCONNECT DOES NOT DISSIPATE VOLTAGE INSIDE THE BATTERY, THE BATTERY PACK REMAINS LIVE AND DANGEROUS. CONTACT WITH THE HIGH-VOLTAGE BATTERY PACK INTERNALS MAY RESULT IN SERIOUS PERSONAL INJURY OR DEATH.

Observe the following precautions when working on or around high-voltage batteries:

- Do not cut the high-voltage battery case. Do not penetrate the batteries or case in any way.
- The high-voltage battery packs are located behind the rear backrest and under the vehicle beneath the upper battery pack location.
- The total voltage of the battery pack is approximately 325 volts DC.
- The battery case is water resistant.
- The battery cells contain a base electrolyte consisting of lithium hexafluorophosphate and organic solvents as the dominant active ingredient, absorbed in special polymeric film. The electrolyte will not leak from the battery under most conditions. However, if the battery is crushed, it is possible for a small amount of electrolyte to leak.

HIGH-VOLTAGE BATTERY PACKS (CONTINUED)

- If possible, isolate and avoid contact with high-voltage vehicle components. If contact with the high-voltage system cannot be avoided, Personal Protective Equipment (PPE) such as a splash shield or safety goggles, gloves (latex, rubber or Nitrile), an apron or overcoat, and rubber boots are required when handling damaged batteries. Exposure to electrolyte could cause skin and/or eye irritation/burns. If exposed, rinse with large amounts of water for 10-15 minutes.
- If the battery is exposed to intense heat (or other extreme conditions), it is possible that flammable gases and liquid (electrolyte) have been released from the cells. Combustible hydrocarbons such as methane, toxic gases such as carbon monoxide, and very small amounts of eye/skin/lung irritants such as hydrofluoric acid could be released from the battery. Take appropriate precautions to make sure the area is properly ventilated, such as opening the vehicle's windows or doors. First responders should wear Personal Protective Equipment (PPE) and self-contained breathing apparatus to safeguard against thermal, electrical, respiratory and skin/eye hazards.

APPROACHING A DAMAGED HIGH-VOLTAGE VEHICLE

 **WARNING: ELECTRIC VEHICLES DAMAGED BY A CRASH MAY HAVE COMPROMISED HIGH VOLTAGE SAFETY SYSTEMS AND PRESENT A POTENTIAL HIGH VOLTAGE ELECTRICAL SHOCK HAZARD. EXERCISE CAUTION AND WEAR APPROPRIATE PERSONAL PROTECTIVE EQUIPMENT (PPE) INCLUDING HIGH VOLTAGE SAFETY GLOVES AND BOOTS. REMOVE ALL METALLIC JEWELRY, INCLUDING WATCHES AND RINGS. ISOLATE THE HIGH VOLTAGE SYSTEM AS DIRECTED BY THE FORD EMERGENCY RESPONSE GUIDE FOR THE VEHICLE. FAILURE TO FOLLOW THESE INSTRUCTIONS MAY RESULT IN SERIOUS PERSONAL INJURY OR DEATH.**

 **WARNING: DAMAGED ELECTRIC VEHICLES SUBMERGED IN WATER PRESENT A POTENTIAL HIGH VOLTAGE ELECTRICAL SHOCK HAZARD. EXERCISE CAUTION AND WEAR APPROPRIATE PERSONAL PROTECTIVE EQUIPMENT (PPE) INCLUDING HIGH VOLTAGE SAFETY GLOVES AND BOOTS. REMOVE ALL METALLIC JEWELRY, INCLUDING WATCHES AND RINGS. DO NOT ATTEMPT TO EXTRACT THE VEHICLE UNTIL THE HIGH VOLTAGE BATTERY HAS DISCHARGED INDICATED BY THE ABSENCE OF BUBBLING OR FIZZING. FAILURE TO FOLLOW THESE INSTRUCTIONS MAY RESULT IN SERIOUS PERSONAL INJURY OR DEATH.**

APPROACHING A DAMAGED HIGH-VOLTAGE VEHICLE (CONTINUED)

 **WARNING:** FIRES IN CRASH-DAMAGED ELECTRIC VEHICLES MAY EMIT TOXIC OR COMBUSTIBLE GASSES. SMALL AMOUNTS OF EYE, SKIN OR LUNG IRRITANTS MAY BE PRESENT. WEAR PERSONAL PROTECTIVE EQUIPMENT (PPE) AND SELF-CONTAINED BREATHING APPARATUS WHEN WORKING IN CLOSE PROXIMITY OR IN A CONFINED AREA, SUCH AS A TUNNEL OR GARAGE. VENTILATE THE VEHICLE INTERIOR BY OPENING VEHICLE WINDOWS OR DOORS. VENTILATE THE WORKING AREA. FAILURE TO FOLLOW THIS INSTRUCTION MAY RESULT IN SERIOUS PERSONAL INJURY OR DEATH.

 **WARNING:** ELECTRIC VEHICLES WITH DAMAGED HIGH VOLTAGE BATTERIES REQUIRE SPECIAL HANDLING PRECAUTIONS. INSPECT THE VEHICLE CAREFULLY FOR LEAKING BATTERY FLUIDS, SPARKS, FLAMES, AND GURGLING OR BUBBLING SOUNDS. CONTACT EMERGENCY SERVICES IMMEDIATELY IF ANY OF THESE PROBLEMS ARE OBSERVED. FAILURE TO FOLLOW THESE INSTRUCTIONS MAY RESULT IN A VEHICLE FIRE AND PERSONAL INJURY OR DEATH.

1. FOLLOW EXISTING TRAINING AND INCIDENT COMMANDER DIRECTION

- Emergency responders should use **LARGE** amounts of water if fire is present or suspected and, keeping in mind that fire can occur for a considerable period after the crash, should proceed accordingly.
- This guide provides only supplemental information as it pertains to the Focus electric vehicles. The same rules apply when approaching any potential high-voltage situation. Always follow your high-voltage safety training. Some precautions to observe in a high-voltage situation include:
 - Remove all jewelry such as watches, necklaces and earrings. Remove all metal objects that are conductors of electricity.
 - Wear the necessary PPEs such as high-voltage rubber gloves, face shield, insulated boots, protective raincoat and apron.
- Bring the following equipment:
 - Class ABC powder-type fire extinguisher.
 - A non-conductive object, about 1.5 m (5 ft) long, to safely push someone away from the vehicle if they accidentally come in contact.

APPROACHING A DAMAGED HIGH-VOLTAGE VEHICLE (CONTINUED)

2. APPROACHING A DAMAGED VEHICLE

- Disable the high-voltage electrical system using as many of the following steps as possible:
 - Secure the vehicle: Place the shift lever into the PARK position. Check that the vehicle ready light is off to verify the high-voltage system is disconnected. If the vehicle ready light is on, press the Start button to turn off the ignition. Block the wheels if necessary.
 - Disconnect the negative cable from the 12-volt battery.
 - If possible, remove the high-voltage service disconnect(s). For additional information, refer to High Voltage Service Disconnect procedures in this manual. If the service disconnects cannot be removed, avoid the high-voltage system components, and wear appropriate PPE as outlined in this guide.
- If the vehicle is on fire, use a Class ABC powder-type extinguisher to contain and smother the flames. If water is being used, **LARGE** amounts of water is required to extinguish the flames. A fire-hydrant or dedicated fire hose can supply the needed amount. Water can cause some degree of arcing/shorting across the cell and/or battery terminals; it can also react with the electrolyte from the cells to generate additional combustible gas and other by products such as hydrofluoric acid. However, the cooling and smothering effects of flushing the affected article with large amounts of water and/or other fire suppression material is still beneficial for minimizing the severity of the event.
- If the vehicle has any exposed cables, wear high-voltage rubber gloves and other appropriate PPE. Do not touch any broken or damaged high-voltage orange cables. Treat severed cables as if they contain high-voltage.
- If the vehicle is submerged in water, varying degrees of arcing/shorting within the battery will take place. Do not touch any high-voltage components or orange cables while removing the occupant(s). Do not remove the vehicle until you are sure the high-voltage battery is completely discharged. A submerged high-voltage battery may produce a fizzing or bubbling reaction to the water. If fizzing or bubbling is observed, the high-voltage battery will be discharged when the fizzing or bubbling has completely stopped. Still treat the battery as if it was not discharged.

APPROACHING A DAMAGED HIGH-VOLTAGE VEHICLE (CONTINUED)

3. HIGH-VOLTAGE SYSTEM - DO NOT CUT ZONES

- If possible, remove the lower and upper battery high-voltage service disconnect(s) before attempting any removal procedure. Always assume the high-voltage cabling and components are powered up.
- If occupant removal is necessary, always use caution when cutting near the vehicle high-voltage system components. Do not cut any of the high-voltage under vehicle or under hood cabling (all high-voltage cabling is orange). High-voltage cabling runs from the high-voltage batteries under the left hand side of the vehicle to the underhood compartment. The vehicle charge port is located on the left front fender. Refer to the diagram below for the no cut zones.

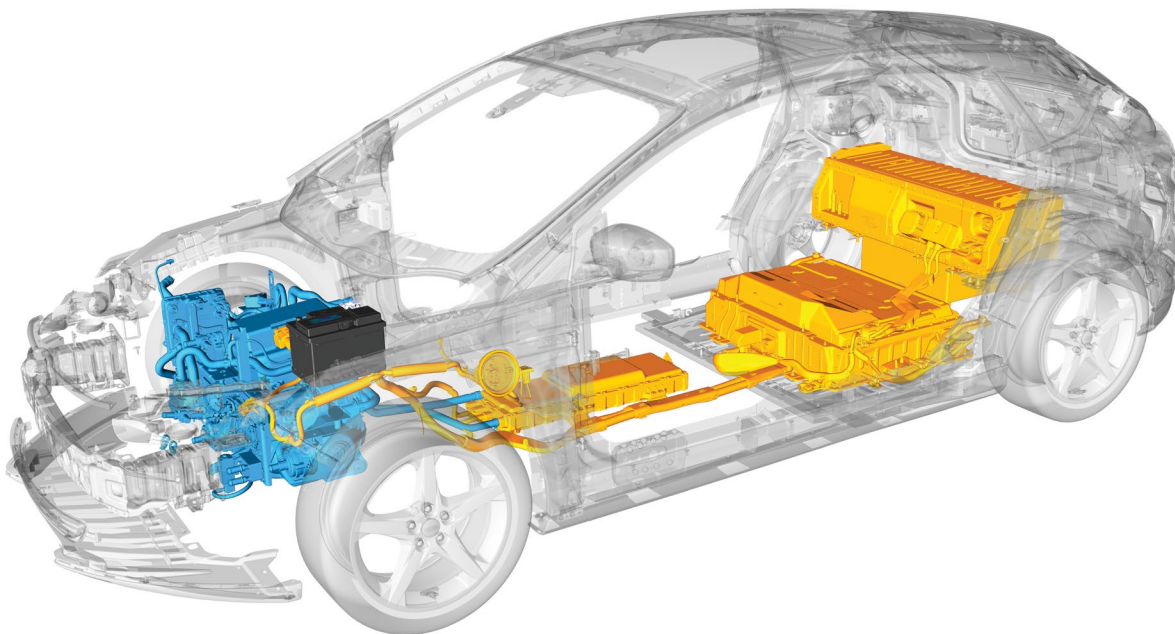

APPROACHING A DAMAGED HIGH-VOLTAGE VEHICLE (CONTINUED)

4. IF THE HIGH-VOLTAGE BATTERY CASE HAS BEEN RUPTURED

- Just like any other battery, hose down the area with **LARGE** amounts of water.

5. MOVING DAMAGED VEHICLES — TOW TRUCK DRIVERS

- **Do not attempt to pull / tow vehicle with all four wheels on the ground as this may cause the vehicle to generate electricity and can cause potential damage.**
- If possible, remove the high-voltage service disconnects. For additional information, refer High Voltage Service Disconnect section in this guide.
- Rather than attempt to discharge a propulsion battery, an emergency responder, tow truck operator, or storage facility manager should contact experts at the vehicle manufacturer.
- Operators of tow trucks and vehicle storage facilities should make sure the damaged vehicle is kept in an open area instead of inside a garage or other enclosed building.
- Follow the guidelines in the Wrecker Towing Guide.
 - Front Tow: Wheel Lift (FWD)
 - Rear Tow: Wheel Lift with Dolly (FWD)
 - Flatbed: FWD
- If you detect leaking fluids, sparks, smoke, flames, increased temperature, gurgling, popping or hissing noises from the high-voltage battery compartment, ventilate the passenger area such as roll down the windows or open doors) and call 911.
- Be alert. There is potential for delayed fire with damaged lithium-ion batteries.
- Call an authorized Ford Dealer or vehicle manufacturer representative, if necessary, to determine the additional steps to take to safely recover or transport the vehicle.
- Always approach the vehicle from the sides to stay out of potential travel path. It may be difficult to determine if the vehicle is running due to lack of engine noise.

APPROACHING A DAMAGED HIGH-VOLTAGE VEHICLE (CONTINUED)

MOVING DAMAGED VEHICLES — TOW TRUCK DRIVERS (CONTINUED)

- Place vehicle into park, set the parking brake, turn off the vehicle, activate the hazard lights, and remove the key fobs to a distance at least 16 feet from the vehicle until loading the vehicle for transport.
- Refer to vehicle manual/recovery guide to locate proper attachment/connection points and transport method.
- Avoid contact with orange high-voltage cabling and areas identified as high-voltage risk by warning labels.

6. ELECTRIC AND HYBRID-ELECTRIC VEHICLE CONSIDERATIONS

In the event of damage to or fire involving an electric vehicle.

- Always assume the High-Voltage (HV) battery and associated components are energized and fully charged.
- Exposed electrical components, wires, and HV batteries present potential HV shock hazards.
- Venting/off-gassing HV battery vapors are potentially toxic and flammable.
- Physical damage to the vehicle or HV battery may result in immediate or delayed release of toxic and/or flammable gases and fire.

Damaged Vehicle Guidance for Ford Motor Company Electric and Hybrid-Electric Vehicles Equipped with High-Voltage Batteries

(Towing and Recovery Operators and Vehicle Storage Facilities)

For questions contact Ford USA 1-800-392-3673 / Ford Canada 1-800-565-3673

In the event of damage or fire involving an Electric Vehicle (EV) or Hybrid-Electric Vehicle (HEV):

- Always assume the HV battery and associated components are energized and fully charged.
- Exposed electrical components, wires and HV batteries present potential HV shock hazards.
- Venting/off-gassing HV battery vapors are potentially toxic and flammable.
- Physical damage to the vehicle or HV battery may result in immediate or delayed release of toxic and/or flammable gases and fire.

Vehicle Shutdown and High-Voltage System Disabling Identify Vehicle

- Determine if the vehicle is an electric or hybrid-electric vehicle, and if it is, advise your dispatch and all other responders that an electric or hybrid-electric vehicle is involved.
- To identify potential symptoms of a damaged high-voltage system, contact an authorized service center or vehicle manufacturer representative. Refer to the Vehicle Owner Manual, Emergency Placard (included in the Vehicle Owner Manual) and/or the Emergency Response Guide for appropriate contact information.
- If you detect leaking fluids, sparks, smoke, flames, increased temperature, gurgling, popping or hissing noises from the HV battery compartment, ventilate the passenger area (such as, roll down windows or open doors) and call 911.
- Be alert. There is a potential for delayed fire with damaged lithium-ion batteries.

Vehicle Recovery/Transportation

- Call an authorized service center or vehicle manufacturer representative, if necessary, to determine additional steps that should be taken to safely recover or transport the vehicle.
- Always approach the vehicle from the sides to stay out of potential travel path. It may be difficult to determine if the vehicle is running due to lack of engine noise.

- Place vehicle into park (P), set the parking brake, turn off the vehicle, activate hazard lights, and remove keys to a distance at least 16 feet from the vehicle until loading the vehicle for transport.
- Refer to vehicle manual/recovery guide to locate proper attachment/connection points and transport method.
- Avoid contact with orange high-voltage cabling and areas identified as high-voltage risk by warning labels.

Vehicle Storage

- **For vehicles in the United States, notify Ford Motor Company 1-800-392-3673 (then follow the prompts on the voice response menu) or an authorized Ford Dealer as soon as possible as there may be additional steps necessary to secure, discharge, handle, and/or store the HV battery and vehicle.**
- **For vehicles in Canada, notify Ford Motor Company 1-800-565-3673 (then follow the prompts on the voice response menu), or an authorized Ford dealer as soon as possible as there may be additional steps necessary to secure, discharge, handle, and/or store the HV battery and vehicle.**
- Do not store a severely damaged vehicle with a lithium-ion battery inside a structure or within 50 feet of any structure or vehicle.
- Make sure the passenger and cargo compartments remain ventilated.
- Prior to placing, and while located in storage area/tow lot, continue to inspect vehicle for leaking fluids, sparks, smoke, flames, gurgling or bubbling sounds from the HV battery and call 911 if any of these are detected.
- Maintain clear access to stored vehicles for monitoring and emergency response if needed.

For specific information and safety preparation regarding the high-voltage system, refer to WWW.MOTORCRAFTSERVICE.COM, select quick guides for the appropriate vehicle emergency response guide.

NOTICE: Never attempt to tow the vehicle with its drive wheels on the ground.

 **WARNING:** ELECTRIC VEHICLES DAMAGED BY A CRASH MAY HAVE COMPROMISED HIGH VOLTAGE SAFETY SYSTEMS AND PRESENT A POTENTIAL HIGH VOLTAGE ELECTRICAL SHOCK HAZARD. EXERCISE CAUTION AND WEAR APPROPRIATE PERSONAL PROTECTIVE EQUIPMENT (PPE) INCLUDING HIGH VOLTAGE SAFETY GLOVES AND BOOTS. REMOVE ALL METALLIC JEWELRY, INCLUDING WATCHES AND RINGS. ISOLATE THE HIGH VOLTAGE SYSTEM AS DIRECTED BY THE FORD EMERGENCY RESPONSE GUIDE FOR THE VEHICLE. FAILURE TO FOLLOW THESE INSTRUCTIONS MAY RESULT IN SERIOUS PERSONAL INJURY OR DEATH.

 **WARNING:** DAMAGED ELECTRIC VEHICLES SUBMERGED IN WATER PRESENT A POTENTIAL HIGH VOLTAGE ELECTRICAL SHOCK HAZARD. EXERCISE CAUTION AND WEAR APPROPRIATE PERSONAL PROTECTIVE EQUIPMENT (PPE) INCLUDING HIGH VOLTAGE SAFETY GLOVES AND BOOTS. REMOVE ALL METALLIC JEWELRY, INCLUDING WATCHES AND RINGS. DO NOT ATTEMPT TO EXTRACT THE VEHICLE UNTIL THE HIGH VOLTAGE BATTERY HAS DISCHARGED INDICATED BY THE ABSENCE OF BUBBLING OR FIZZING. FAILURE TO FOLLOW THESE INSTRUCTIONS MAY RESULT IN SERIOUS PERSONAL INJURY OR DEATH.

 **WARNING:** FIRES IN CRASH-DAMAGED ELECTRIC VEHICLES MAY EMIT TOXIC OR COMBUSTIBLE GASSES. SMALL AMOUNTS OF EYE, SKIN OR LUNG IRRITANTS MAY BE PRESENT. WEAR PERSONAL PROTECTIVE EQUIPMENT (PPE) AND SELF-CONTAINED BREATHING APPARATUS WHEN WORKING IN CLOSE PROXIMITY OR IN A CONFINED AREA, SUCH AS A TUNNEL OR GARAGE. VENTILATE THE VEHICLE INTERIOR BY OPENING VEHICLE WINDOWS OR DOORS. VENTILATE THE WORKING AREA. FAILURE TO FOLLOW THIS INSTRUCTION MAY RESULT IN SERIOUS PERSONAL INJURY OR DEATH.

 **WARNING:** ELECTRIC VEHICLES WITH DAMAGED HIGH VOLTAGE BATTERIES REQUIRE SPECIAL HANDLING PRECAUTIONS. INSPECT THE VEHICLE CAREFULLY FOR LEAKING BATTERY FLUIDS, SPARKS, FLAMES, AND GURLING OR BUBBLING SOUNDS. CONTACT EMERGENCY SERVICES IMMEDIATELY IF ANY OF THESE PROBLEMS ARE OBSERVED. FAILURE TO FOLLOW THESE INSTRUCTIONS MAY RESULT IN A VEHICLE FIRE AND PERSONAL INJURY OR DEATH.

DAMAGED BATTERY ELECTRIC VEHICLE STORAGE PLACARD

- If the vehicle and/or battery high-voltage system is damaged, place a sign indicating that it is a battery electric vehicle with potentially dangerous high-voltage. See example below:

**WARNING:
BATTERY ELECTRIC VEHICLE WITH
POSSIBLE HIGH VOLTAGE SYSTEM
DAMAGE. DO NOT TOUCH!**

**WARNING:
BATTERY ELECTRIC VEHICLE WITH
POSSIBLE HIGH VOLTAGE SYSTEM
DAMAGE. DO NOT TOUCH!**

Copyright 2015, Ford Motor Company. All rights reserved. This document may be reproduced in its entirety and distributed for emergency responder use only. It may not be excerpted for any purpose.